



# COMMUNITY ADVISORY GROUP



MEETING #26 – 23 MAY 2024



# ACKNOWLEDGEMENT OF COUNTRY

WE ACKNOWLEDGE THE GUNAIKURNAI PEOPLE AS THE TRADITIONAL CUSTODIANS OF THE LAND AND PAY RESPECT TO THEIR ELDERS PAST AND PRESENT

# AGENDA

## 1. Welcome

## 2. Standing items and actions

- Apologies
- Minutes and action items
- Declaration of potential conflicts

## 3. Focus topic

- Southerly Ten response to proposed Offshore Electricity Infrastructure Act 2021 regulations

## 4. Focus topic

- Fishing insights from visit to Vineyard Offshore Wind Project

## 5. Break (10 minutes)

## 6. What's happening on the project

## 7. What's happening in the community

## 8. Other business

- Other questions or feedback
- Key messages
- Suggestions for future agenda items
- Next meeting – 4 July 2024

## 9. Meeting close

# FOCUS TOPIC

SOUTHERLY TEN RESPONSE TO PROPOSED OFFSHORE ELECTRICITY  
INFRASTRUCTURE (OEI) ACT 2021 REGULATIONS

# DRAFT REGULATIONS OVERVIEW

## About the regulations

- The OEI Regulations have been long awaited (since 2022) and cover how the OEI Act will be implemented in practice.
- 36 questions drawing attention to certain sections of the regulations.
- Topics covered in the consultation paper questions were based around the categories:
  - Management Plans
  - Design Notification Scheme
  - Financial Security
  - Safety zones and protection zones
  - Work health and safety
  - Record-keeping
  - Data management
  - Fees
  - Updates to the licensing scheme

## How we responded

- 44-page submission incorporating commentary on key topics and answers to questions.
- Our main feedback:
  - Adjusting details to reduce unnecessary delays or inefficiencies.
  - Caution when adopting oil and gas regulation due to differing risk levels, and differing investor risk approaches due to the differing revenue models.

## Next Steps

- OIR (Nopsema) released their interpretation of the draft regulations and have a workshop June 13 with industry.
- Targeted interaction with government on our submission.
- Transmission Licence consultation has now been released for comment, which we will also comment on.

# DRAFT REGULATIONS – OUR KEY POINTS

## Management Plans

- Proposing practical solutions to streamline the process, avoiding duplication of existing requirements, administrative burden, unnecessary delays and proposing flexibility in consultation requirements to avoid 'box ticking' and consultation fatigue with local communities.

## Design Notification Scheme

- Recommending that the Design Notification Scheme be a value-added process in concert with the Regulator and not duplicating what exists in other regulatory processes.

## Financial Security

- Ensuring financial security requirements are aligned against global standards to avoid unnecessary barriers to investment and increased cost burden on consumers.

## Safety Zones and Protection Zones

- Supporting the shared use of the marine space by not prescribing maximum areas for safety and protection zones and instead working with marine users on workable solutions through Management Plans, while encouraging greater clarity for stakeholders in 'plain English'.

## Work Health and Safety

- Strengthening work health and safety outcomes through reducing complexity and ensuring Australia grows its local skills and capability in line with global best practice for specialised offshore work.

## Fees

- Regulator fees are based on expenses incurred with no cost cap. Such a cost structure represents a significant and unacceptable investment risk related to time periods and costs, for a project with a fixed and likely capped level of revenue.

# STAR OF THE SOUTH UPDATE

## Recent achievements

- Completion of EIF (Energy Innovation Fund) grant scope.
- Onshore and offshore geotech, ports studies, transmission development, local industry, ports and harbours, offshore environment specialist reports, workforce transition.

## Focus for the next 12 months

- Setup processes for licence compliance.
- Continue to progress approvals of the project.
- Work with VicGrid on new transmission connection solution.
- Supplier market engagement.
- Work with government to prepare for the first auction (scheduled for submission early 2026 with award in late 2026).

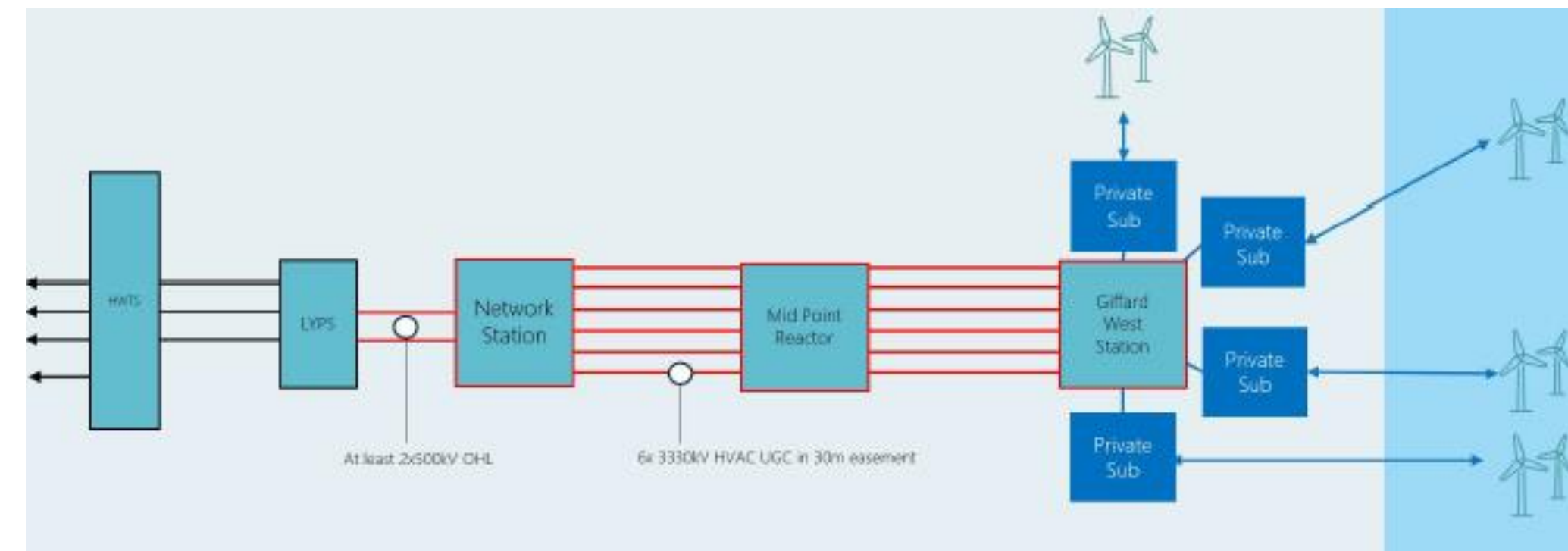
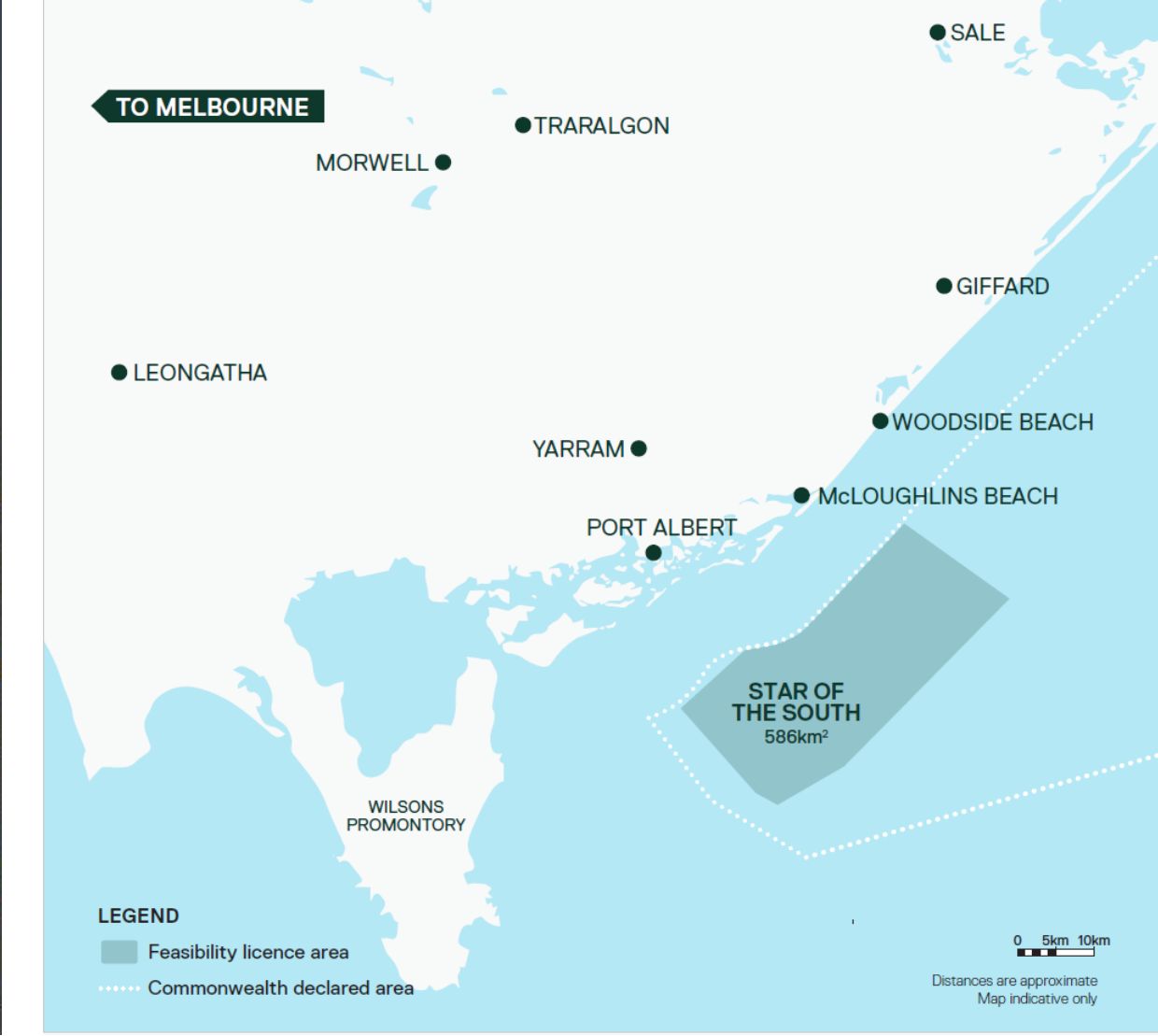

# KUT-WUT BRATAUALUNG UPDATE

## What's next

- Setup the project team and processes, with a focus on licence compliance.
- Identify timing of when this project will have the best value proposition.
  - Clarity on Victorian government rolling auction timeline
  - Competitor analysis.
- Maturing transmission strategy
  - Kut-wut Brataualung gives a unique transmission option both to Victoria and/or Tasmania
  - Work with VicGrid on opportunity to explore alternative grid solutions to the current plan in Gippsland.
- Consider options for start of marine activities (floating LiDAR, marine environment survey program).



# FOCUS TOPIC

FISHING INSIGHTS FROM VISIT TO VINEYARD  
OFFSHORE WIND PROJECT

# LACHLANS VINEYARD WIND TRIP

18-22 MARCH 2024

## Purpose

Observe Vineyard Wind fishing liaison team roll-out their 'Fishing Compensation Mitigation Program' in New Bedford and Hyannis (Massachusetts) and Point Judith (Rhode Island).

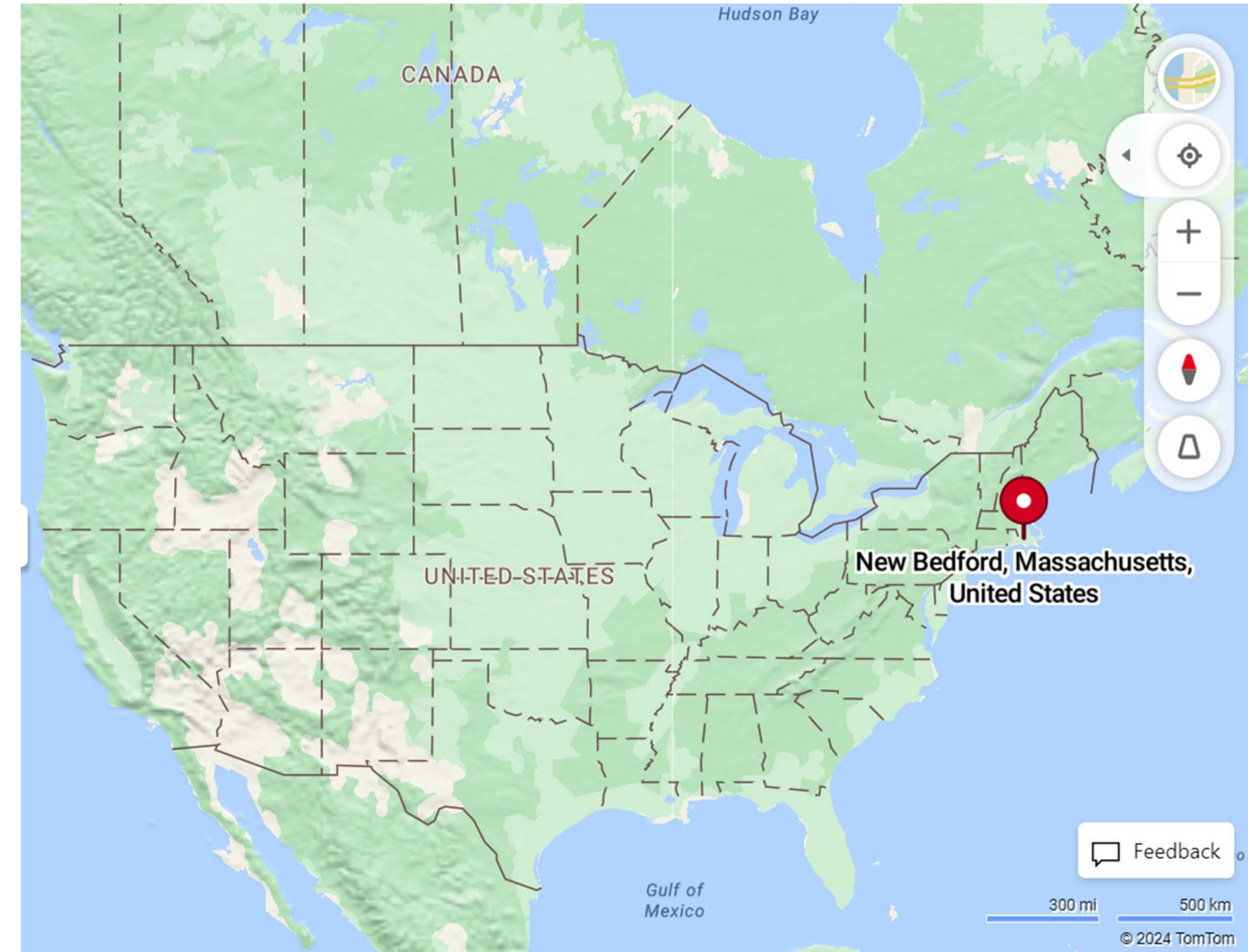

# ABOUT THE PROJECT

- Vineyard Wind 1 is one of 9 projects off the New England Coast
- 250 km<sup>2</sup>
- Approx 25 km from shore
- 62 turbines, 800 MW
- Monopile foundations
- 1 NM apart
- 15 completed operating turbines
- 22 transition pieces
- 13 monopiles
- 12 WTG



# ABOUT THE PROJECT

- Vineyard Wind 1 is one of 9 projects off the New England Coast
- 250 km<sup>2</sup>
- Approx 25 km from shore
- 62 turbines, 800 MW
- Monopile foundations
- 1 NM apart
- 15 completed operating turbines
- 22 transition pieces
- 13 monopiles
- 12 WTG

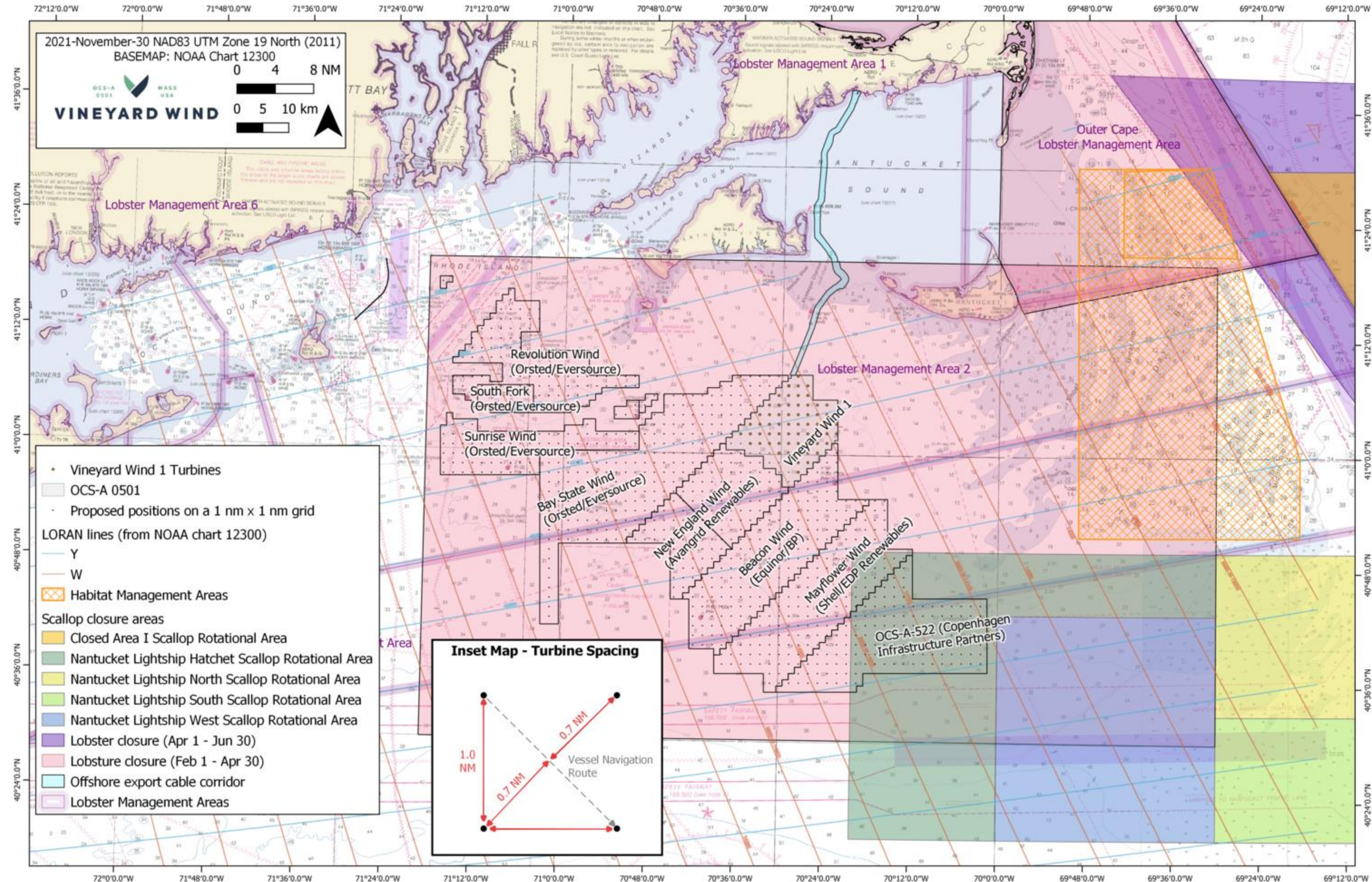

# PORT OF NEW BEDFORD

- Formerly world's largest whaling port
- Scallops: \$400M, approximately 200 boats
- Lobster: \$100M, 39 boats
- Estimated 96 boats from Massachusetts & Rhode Island use Vineyard Wind 1 area
- Boats from New Jersey, Connecticut & New York also
- Despite difference in size, many similarities between USA & Australia.

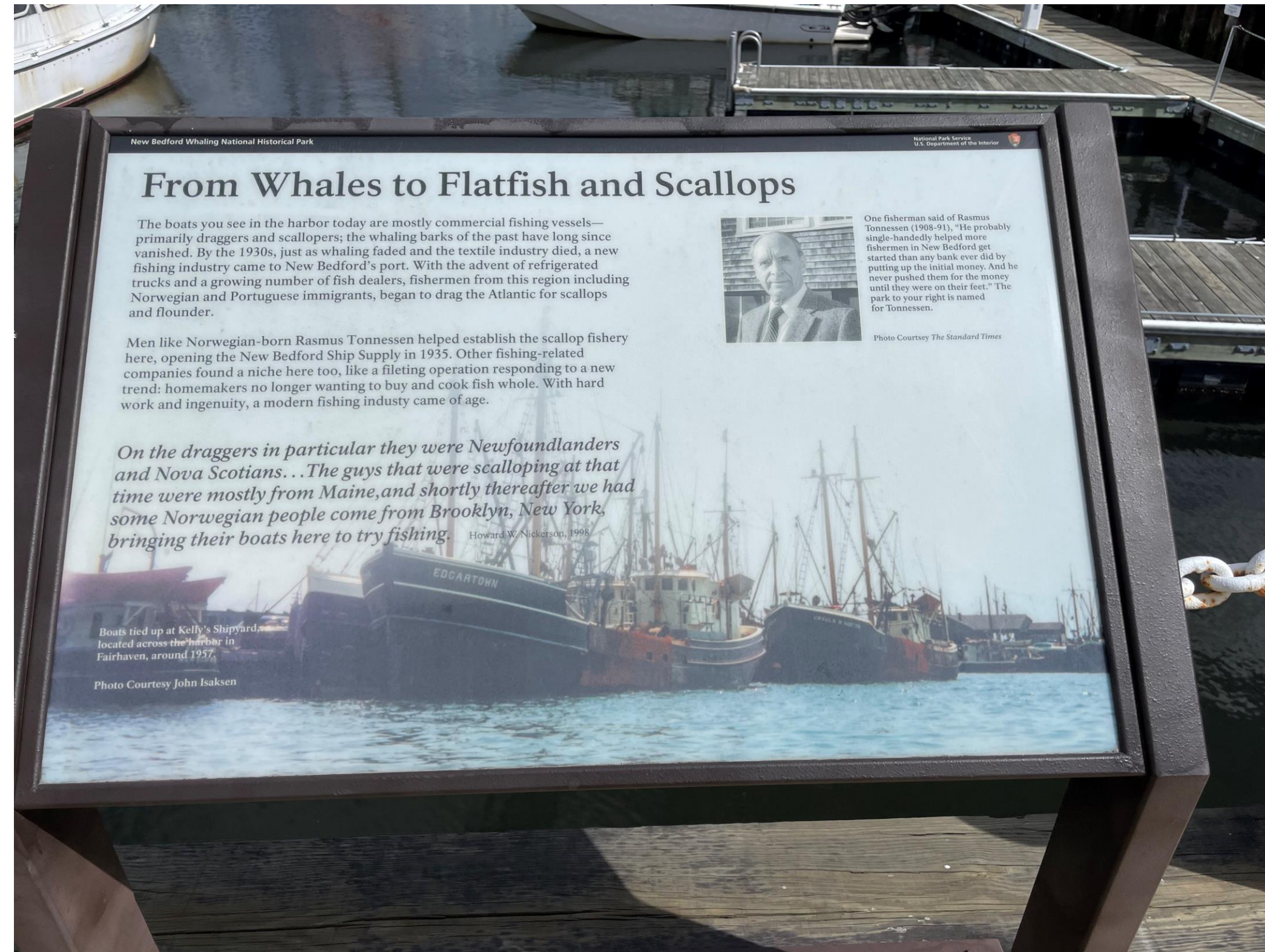

# COMPENSATION PROGRAM

- Direct compensation and Industry Benefit fund(s)
- States calculate commercial value (%) of area
- States determine split between direct compensation and industry benefit fund
  - Massachusetts 90% direct, 10% benefit fund
  - Rhode island 25% direct, 75% benefit fund
- Fishermen have 90 days (March - June 2024) to lodge a claim
- Shoreside businesses can also claim
  - Only following fishermen's claim period.



# DIRECT COMPENSATION

- Fishermen must prove eligibility
  - Catch & sales records
  - Plotter images
  - NMFS data
  - Vessel currently registered
  - Catch history 2016-2022
- Expedited claim
  - VW determines compensation
- Individual claim
  - Fishermen can demonstrate higher compensation payable
  - Does not disqualify from expedited claim
- Fishing representatives
  - Validates claim & data
- Independent administrator
  - Calculates & makes payment
- Annual payments for 5 years
  - Review for further payments
- Shoreside businesses can claim
  - Leftover funds from direct compensation component



# INDUSTRY BENEFIT FUNDS

- Established by the states
- Fisheries innovation fund
  - Grants to support R&D
  - Impacts of offshore wind
  - Fishing vessel & gear improvements etc.
- Coastal community fund
  - Grants to support recreational fishing
  - Charter operators
  - Training
  - Marketing
  - Infrastructure
- Navigational enhancement and training fund



# REGIONAL FUND ADMINISTRATION

- Currently there is a different approach to compensation between developers
- Vineyard Wind is seen as an industry leader
- The intention is for a RFA to be established over next 2 years
  - All developers and states to participate
  - One streamlined process for compensation
  - Fair for fishermen and developers



# WATERFRONT MOBILE APP

- Information can be streamlined and customized to your preferences, i.e., project specific
- Mariner updates – free AIS data, with real time information between all vessels
- Mapping
- Chat with marine friends and engage directly with marine projects
- Notifications and alerts
- Control your data all from one place

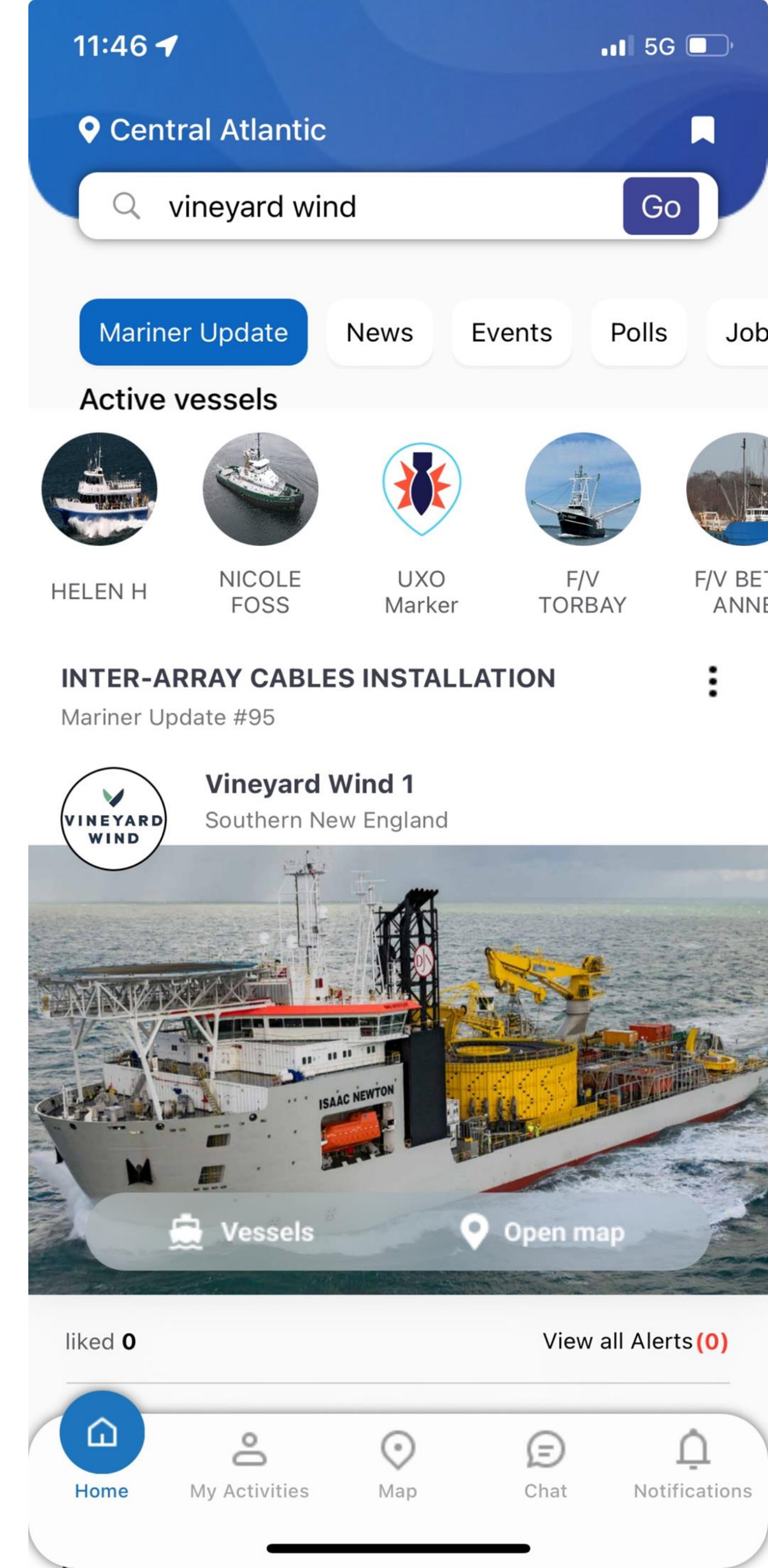

# KEY LEARNINGS

- Different scale and management of commercial fisheries between USA and Australia
- There is cooperation between projects
- Liberal approach to coexistence
  - Minimal restrictions on fishing post construction and during operations
  - No limits on anchoring, trawling
  - No safety zones
  - Benefit sharing
- Regional approach to compensation
- Vineyard Wind is the industry leader
  - perceived as flexible and fair
- Similar response and concerns from commercial fishing sector re offshore wind



BREAK

# WHAT'S BEEN HAPPENING ON THE PROJECT

Launch of **Southerly Ten** – a specialist offshore wind energy developer for Australia and New Zealand

## Events and presentations

- Catholic College Sale, Yr. 11 students
- Surfers for Climate – Trivia with Peninsula Surf Sisters
- ABC News Breakfast, (Television)
- ABC Gippsland Breakfast, (Radio)
- South Gippsland Jobs Expo
- Trade & Tech Fit Career Expo
- South-East Australia Transport Strategy
- Victorian Seafood Industry Awards
- CEDA VIC state budget address with Tim Pallas
- VicGrid drop-in session – Leongatha:

Draft Renewable Energy Zone Community Benefits Plan

[www.engage.vic.gov.au/vtif-rez-community-benefits](http://www.engage.vic.gov.au/vtif-rez-community-benefits)



# WHAT'S COMING UP

## Events and presentations

- Fish Creek Tea Cosy Festival – Market Day
- Youth Careers Expo, Bairnsdale
- Arawata Landcare
- South Gippsland Bass Coast LLEN – Careers Expo, Korumburra
- IPA Victorian Breakfast Series



# WHAT'S HAPPENING IN THE COMMUNITY

## Community updates – open to all members

- What are you hearing?
- What are the hot topics in your local area?
- Would you like to give a more in-depth update at the next meeting on an upcoming event?



# OTHER BUSINESS

# OTHER BUSINESS

## & FORWARD MEETING SCHEDULE

Other questions and feedback?

- Suggestions for future agenda items
- List on the CAG Member Teams Page 'files'
  - Email / call Jason

**Next meeting** - 4 Jul. 2024 in South Gippsland, (Venue TBC)

---

Date	Location	Topic (tentative, subject to change)
21 Aug. 2024	Latrobe Valley (Venue TBC)	(TBC)
26 Sept. 2024	Sale (Venue TBC)	(TBC)

Thank you for your participation

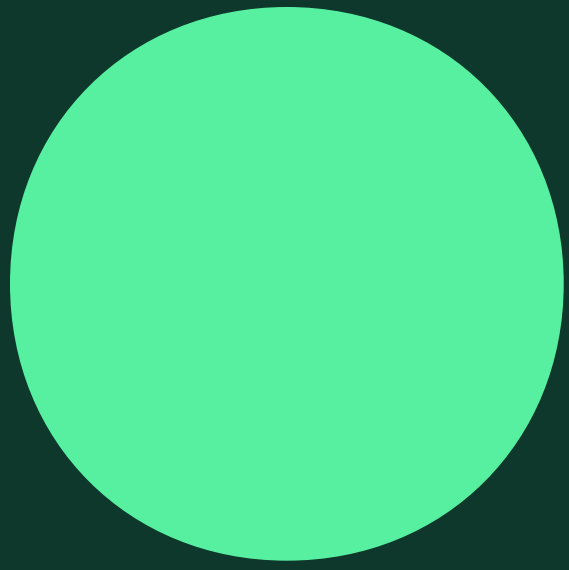

● Y SOUTHERLY  
↓ >> TEN

Level 30, 55 Collins Street,  
Melbourne, Victoria 3000 Australia

Office: (03) 9108 4000 Community:  
1800 340 340

[info@southerlyten.com.au](mailto:info@southerlyten.com.au)  
[southerlyten.com.au](http://southerlyten.com.au)

